



# Standard Test Method for Static and Kinetic Coefficients of Friction of Plastic Film and Sheeting<sup>1</sup>

This standard is issued under the fixed designation D1894; the number immediately following the designation indicates the year of original adoption or, in the case of revision, the year of last revision. A number in parentheses indicates the year of last reapproval. A superscript epsilon ( $\epsilon$ ) indicates an editorial change since the last revision or reapproval.

*This standard has been approved for use by agencies of the U.S. Department of Defense.*

## 1. Scope\*

1.1 This test method covers determination of the coefficients of starting and sliding friction of plastic film and sheeting when sliding over itself or other substances at specified test conditions. The procedure permits the use of a stationary sled with a moving plane, or a moving sled with a stationary plane. Both procedures yield the same coefficients of friction values for a given sample.

NOTE 1—For the frictional characteristics of plastic films partially wrapped around a cylinder, or capstan, see Test Method G143 under the jurisdiction of ASTM Subcommittee G02.50.

1.2 Test data obtained by this test method is relevant and appropriate for use in engineering design.

1.2.1 As an option to this test, coefficient of friction may be run at temperatures other than 23°C by heating only the plane while the sled is at ambient temperature.

1.3 The values stated in SI units are to be regarded as standard. The values given in parentheses are for information only.

1.4 *This standard does not purport to address all of the safety concerns, if any, associated with its use. It is the responsibility of the user of this standard to establish appropriate safety and health practices and determine the applicability of regulatory limitations prior to use.* For a specific precautionary statement, see the end of 6.5.

NOTE 2—This test method is not equivalent to ISO 8295–1995, and results cannot be directly compared between the two methods.

## 2. Referenced Documents

### 2.1 ASTM Standards:<sup>2</sup>

D618 Practice for Conditioning Plastics for Testing

<sup>1</sup> This test method is under the jurisdiction of ASTM Committee D20 on Plastics and is the direct responsibility of Subcommittee D20.19 on Film, Sheeting, and Molded Products.

Current edition approved March 1, 2014. Published March 2014. Originally approved in 1961. Last previous edition approved in 2011 as D1894 - 11<sup>ε1</sup>. DOI: 10.1520/D1894-14.

<sup>2</sup> For referenced ASTM standards, visit the ASTM website, www.astm.org, or contact ASTM Customer Service at service@astm.org. For *Annual Book of ASTM Standards* volume information, refer to the standard's Document Summary page on the ASTM website.

D883 Terminology Relating to Plastics

D1894 Test Method for Static and Kinetic Coefficients of Friction of Plastic Film and Sheeting

D3574 Test Methods for Flexible Cellular Materials—Slab, Bonded, and Molded Urethane Foams

D4000 Classification System for Specifying Plastic Materials

E177 Practice for Use of the Terms Precision and Bias in ASTM Test Methods

E691 Practice for Conducting an Interlaboratory Study to Determine the Precision of a Test Method

G143 Test Method for Measurement of Web/Roller Friction Characteristics

2.2 ISO Standard:

ISO 8295–1995<sup>3</sup>

## 3. Terminology

### 3.1 Definitions:

3.1.1 *friction, n*—resistance to relative motion between two bodies in contact.

3.1.1.1 *coefficient of friction*—the ratio of the force required to move one surface over another to the total force applied normal to those surfaces.

3.1.1.2 *kinetic coefficient of friction*—the ratio of the force required to move one surface over another to the total force applied normal to those surfaces, once that motion is in progress.

3.1.1.3 *static coefficient of friction*—the ratio of the force required to move one surface over another to the total force applied normal to those surfaces, at the instant motion starts.

### 3.2 Definitions of Terms Specific to This Standard:

3.2.1 *slip—in plastic films*, lubricity of two surfaces sliding in contact with each other.

## 4. Significance and Use

4.1 Measurements of frictional properties may be made on a film or sheeting specimen when sliding over itself or over

<sup>3</sup> Available from American National Standards Institute (ANSI), 25 W. 43rd St., 4th Floor, New York, NY 10036, http://www.ansi.org.

\*A Summary of Changes section appears at the end of this standard

another substance. The coefficients of friction are related to the slip properties of plastic films that are of wide interest in packaging applications. These methods yield empirical data for control purposes in film production. Correlation of test results with actual performance can usually be established.

4.1.1 This test method includes testing at temperatures other than 23°C by heating only the plane while the sled is at ambient temperature.

4.2 Slip properties are generated by additives in some plastic films, for example, polyethylene. These additives have varying degrees of compatibility with the film matrix. Some of them bloom, or exude to the surface, lubricating it and making it more slippery. Because this blooming action may not always be uniform on all areas of the film surface, values from these tests may be limited in reproducibility.

4.3 The frictional properties of plastic film and sheeting may be dependent on the uniformity of the rate of motion between the two surfaces. Care should be exercised to ensure that the rate of motion of the equipment is as carefully controlled as possible.

4.4 Data obtained by these procedures may be extremely sensitive to the age of the film or sheet and the condition of the surfaces. The blooming action of many slip additives is time-dependent. For this reason, it is sometimes meaningless to compare slip and friction properties of films or sheets produced at different times, unless it is desired to study this effect.

4.5 Frictional and slip properties of plastic film and sheeting are based on measurements of surface phenomena. Where products have been made by different processes, or even on different machines by the same process, their surfaces may be dependent on the equipment or its running conditions. Such factors must be weighed in evaluating data from these methods.

4.6 The measurement of the static coefficient of friction is highly dependent on the rate of loading and on the amount of blocking occurring between the loaded sled and the platform due to variation in time before motion is initiated.

4.7 Care should be exercised to make certain that the speed of response of the recorder, either electronic or mechanical, is not exceeded.

4.8 For many materials, there may be a specification that requires the use of this test method, but with some procedural modifications that take precedence when adhering to the specification. Therefore, it is advisable to refer to that material specification before using this test method. Table 1 of Classification System **D4000** lists the ASTM materials standards that currently exist.

## 5. Apparatus

5.1 *Sled*—A metal block 63.5-mm (2½-in.) square by approximately 6-mm (0.25-in.) thick with a suitable eye screw fastened in one end. When a flexible film (see 6.2) is to be attached, the block shall be wrapped with a sponge rubber 63.5 mm (2½ in.) in width and 3.2 mm (⅛ in.) in thickness. The foam shall be flexible, smooth-faced, and have a nominal density of 0.25 g/cm<sup>3</sup> when measured in accordance with the

Density Test of Methods **D3574**. The pressure required to compress the foam 25 % shall be 85 ± 15 kPa (12.5 ± 2.5 psi). The foam shall also have a high hysteresis when deformed.<sup>4</sup> The rubber shall be wrapped snugly around the sled and held in place against the bottom and top of the sled with double-faced masking tape. When a sheet (see 6.3) is to be attached, double-faced tape shall be used to attach the specimen. The total weight of the (wrapped) sled and specimen shall be 200 ± 5 g.

NOTE 3—Round-robin testing<sup>5</sup> has shown that the physical properties of the backing can drastically affect both the coefficient of friction and stick-slip behavior of the film.

5.2 *Plane*—A polished plastic, wood, or metal sheet,<sup>6</sup> approximately 150 by 300 by 1 mm (6 by 12 by 0.040 in.). A smooth, flat piece of glass may cover the upper surface of the plane. This provides a smooth support for the specimen.

5.2.1 When it is desirable to run tests at temperatures above 23°C, a heating unit shall be provided that is capable of maintaining the temperature of the plane within ±2°C of the desired temperature. The temperature should be maintained within ±2°C of the desired temperature over the entire traverse of the sled (that is, over the full surface of the plane).

NOTE 4—If the equipment has a plane with a heater, a cover may be used to help maintain the temperature of the plane within ±2°C of the desired temperature.

5.3 *Scissors or Cutter*, suitable for cutting specimens to the desired dimensions.

5.4 *Adhesive Tape*, cellophane or pressure-sensitive.

5.5 *Adhesive Tape*, double-faced.

5.6 *Nylon Monofilament*, having a 0.33 ± 0.05-mm (0.013 ± 0.002-in.) diameter and capable of supporting a 3.6-kg (8-lb) load.

5.7 *Beaded Chain*, flexible metal cable, or equivalent, having a spring rate no less than 600 lbs per inch of stretch per inch of length (40 lbs/in. (7000 N/m) for a 15-in. chain) in the range of 50 to 150 g of tension (such as beaded lampswitch pull chain).

5.8 *Low-Friction Pulleys*—A phenolic type pulley mounted in hardened steel cone bearings on a metal fork. A ball-bearing type pulley may also be used.

5.9 *Force-Measuring Device*, capable of measuring the frictional force to ±5 % of its value. A spring gauge<sup>7</sup> (see **Note 5**), universal testing machine, or strain gauge may be used.

NOTE 5—The capacity of the spring gauge (**Fig. 1(a and b)**) needed will depend upon the range of values to be measured. For most plastic, a 500-g

<sup>4</sup> Sleds pre-wrapped with sponge rubber are commercially available from a number of suppliers.

<sup>5</sup> Supporting data are available from ASTM Headquarters. Request RR:D20-1065.

<sup>6</sup> Acrylic or rigid poly(vinyl chloride) sheeting has been found satisfactory for this purpose.

<sup>7</sup> The sole source of supply of the Model L-500 known to the committee at this time is Hunter Spring Co., Lansdale, PA. If you are aware of alternative suppliers, please provide this information to ASTM International Headquarters. Your comments will receive careful consideration at a meeting of the responsible technical committee,<sup>1</sup> which you may attend.

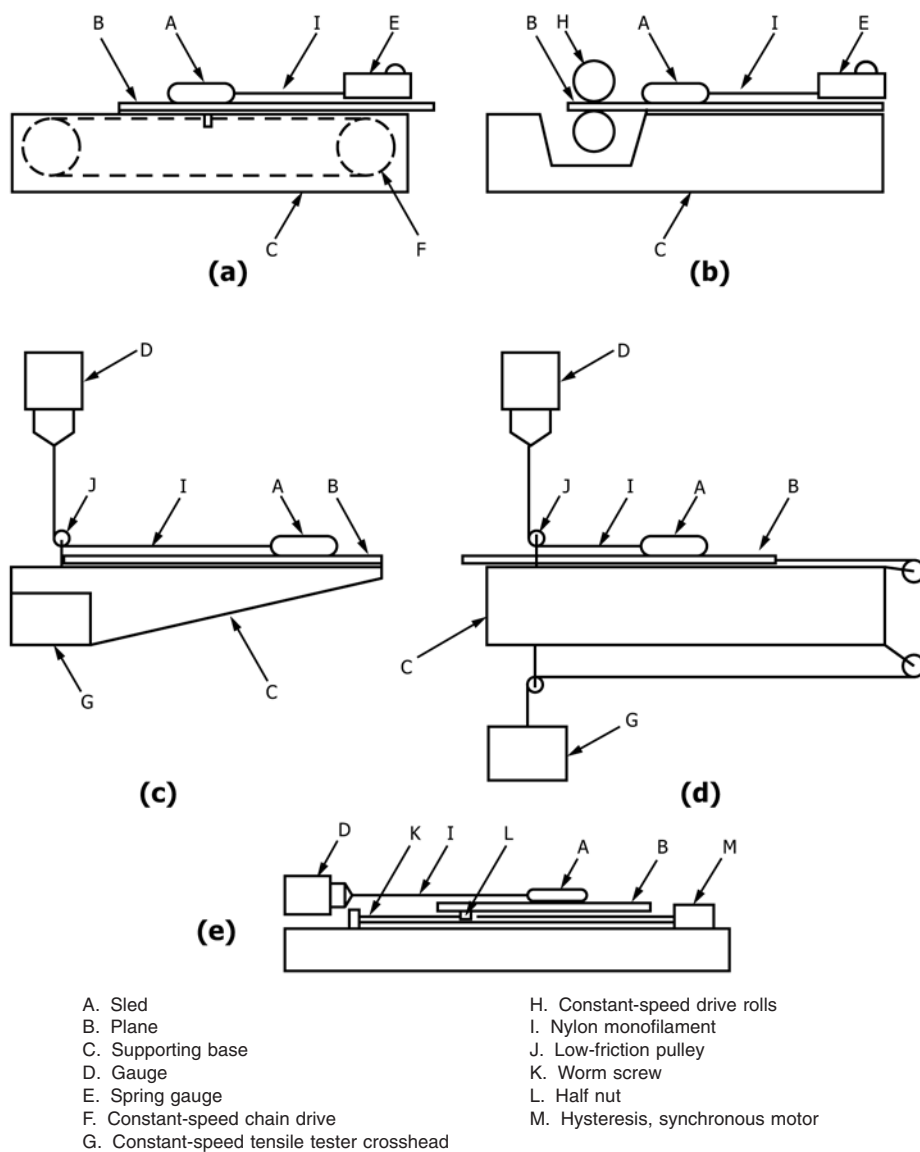

FIG. 1 Five Methods of Assembly of Apparatus for Determination of Coefficients of Friction of Plastic Film

capacity gauge with 10-g or smaller subdivisions will be satisfactory. This spring will measure coefficients of friction up to and including 2.5.

5.10 *Supporting Base*—A smooth wood or metal base approximately 200 by 380 mm (8 by 15 in.) is necessary to support the plane. The supporting base may be a simple rectangular box. If a universal testing machine is used to pull a moving plane, a supporting base of sufficient structural strength and rigidity to maintain a firm position between the moving crosshead and the force-measuring device will be necessary.

5.11 *Driving or Pulling Device for Sled or Plane*—The plane may be pulled by a driven pair of rubber-coated rolls not less than 200 mm (8 in.) long, capable of maintaining a uniform surface speed  $150 \pm 30$  mm/min ( $0.5 \pm 0.1$  ft/min) (Fig. 1(b)), by the crosshead of a universal testing machine (Fig. 1(d)) (see Note 6), or a worm drive driven with a synchronous motor (Fig. 1(e)). A constant-speed chain drive system has also been found satisfactory (Fig. 1(a)). A power-

operated source may be used for pulling the sled over the horizontally-mounted specimen at a uniform speed of  $150 \pm 30$  mm/min ( $0.5 \pm 0.1$  ft/min). A universal testing machine equipped with a load cell in its upper crosshead and a constant rate-of-motion lower crosshead has been found satisfactory (see Fig. 1(c)).

NOTE 6—Where the moving crosshead of a universal testing machine is used to pull the moving plane through a pulley system (Fig. 1(d)), the strain gauge load cell, or other load-sensing instrument in the testing machine, acts as the force-measuring device.

## 6. Test Specimens

6.1 The test specimen that is to be attached to the plane shall be cut approximately 250 mm (10 in.) in the machine direction and 130 mm (5 in.) in the transverse direction when such extrusion directions exist and are identifiable.

6.2 A film specimen that is to be attached to the sled shall be cut approximately 120-mm (4½-in.) square. Film is defined as